

Cytron
Technologies

SN-E18-B03N1
Digital Infrared Sensor



User's Manual

V1.1

July 2012

Information contained in this publication regarding device applications and the like is intended through suggestion only and may be superseded by updates. It is your responsibility to ensure that your application meets with your specifications. No representation or warranty is given and no liability is assumed by Cytron Technologies Incorporated with respect to the accuracy or use of such information or infringement of patents or other intellectual property rights arising from such use or otherwise. Use of Cytron Technologies's products as critical components in life support systems is not authorized except with express written approval by Cytron Technologies. No licenses are conveyed, implicitly or otherwise, under any intellectual property rights.

Index

1. Introduction and Overview	3
2. Packing List	4
3. Product Specification and Limitations	5
4. Product Dimension and Layout	7
5. Getting Started	9
6. Warranty	11

1. INTRODUCTION AND OVERVIEW

This Digital Infrared Sensor offers simple, user friendly and fast obstacle detection using infrared. This is an Digital Infrared Sensor. This product is used during the reflection of IR by obstacles. It is widely to use in various type of industry such as spinning and weaving, mechanical, iron and steel, chemical,electric power, security and so on.This product features include:

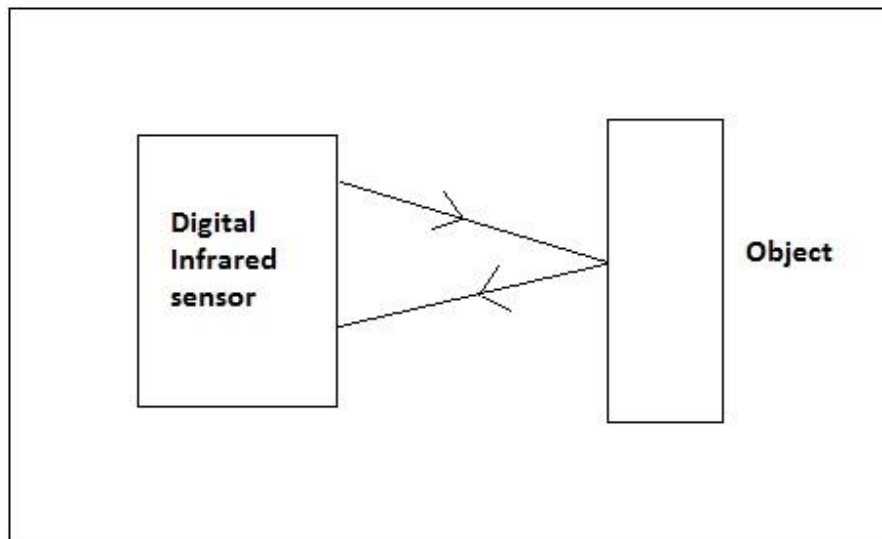

Figure 1.1 The reflection of Digital Infrared Sensor on the object

- Cylindrical, diffuse reflectance
- *NPN output
- Three-wire.
- ****6V-36V powered, low current consumption, less than 300mA.**
- *****Obstacle detection up to 30cm.**
- **Adjustable sensing range (0cm-30cm).**
- Small size makes it easy to assembly.
- High precision, waterproof, protect corrosion, resist of light.
- Widely useful for robot,interactive media,industrial assembly,etc.

* Though it is NPN output, but internally it is being pull up the power pin.

** Test show it can be powered as low as 5V.

*** Longer distance can be achieve if power voltage is increase.

2. PACKING LIST

Please check the parts and components according to the packing lists. If there are any parts missing ,please contact us at sales@cytron.com.my immediately.



1. 1 x SN-E18-B03N1 sensor module.

3. PRODUCT SPECIFICATION AND LIMITATIONS

3.1 Theory of Operation

The SN-E18-B03N1 contains infrared sensor for use as reflection of IR signal barriers. It uses special sensor to detect the modulated IR signal reflected back from a nearby either or a far distance of the object. The transmitter and the receiver between the light intensity of the digital infrared sensor can change into for the purpose of current changes in order to achieve the detection. The output signal of Digital Infrared Sensor is needed to be pull high as it is NPN output. The module will output a HIGH if no object is detected and a LOW if an object is detected.

Note: Although the specification stated it is NPN output, we notice the sensor itself is being pull-up internally. Causing the output pin is being pull up to power pin. So if 12V is supply, you will get ~12V at output when no obstacle is detected.

3.2 Pin Definitions and Ratings

Color	Name	Function
Brown	VCC	Connects to VCC (+6V to +36V)
Blue	Ground	Connects to Ground
Black	Output Signal	Connect to an I/O pin of microcontroller which set to INPUT mode

Absolute Maximum Rating

Parameter	Min	Max	Unit
Operating voltage	6	36	V
Sensing meter	0	30	cm

Lab test result show even as low as 5V the sensor can still function. Yet, we do no test for all sensor.

3.3 Sensitivity

The Digital Infrared Sensor has a sensing range of approximately 0cm to 30m for a white or shiny color object. For a dark or black color object, the Digital Infrared Sensor has a sensing range of approximately 2cm to 25cm. It shows that the sensor will reflect more on a white surface than a black surface. The sensor is designed to adjustable sensing range. When user adjust the white preset (at the bottom of Digital Infrared Sensor, the range object detected also change. If user adjust the preset to counter-clockwise, the detected range will less than 30cm. The more user adjust the preset to counter clockwise, the more short the Digital Infrared sensor may detect object.



3.4 Test Result in Lab

We have tested the sensor in our lab with different voltage and here is the result.

Voltage, V	Maximum detectable distance (obstacle)
5V	20cm
12V	60cm
30V	80cm

All test is using Cytron's packaging white color box as obstacle. Other object might have different result as it depends on the reflective of Infrared of object surface. The above result is just for reference.

4.PRODUCT DIMENSION AND LAYOUT

4.1 Product Dimension

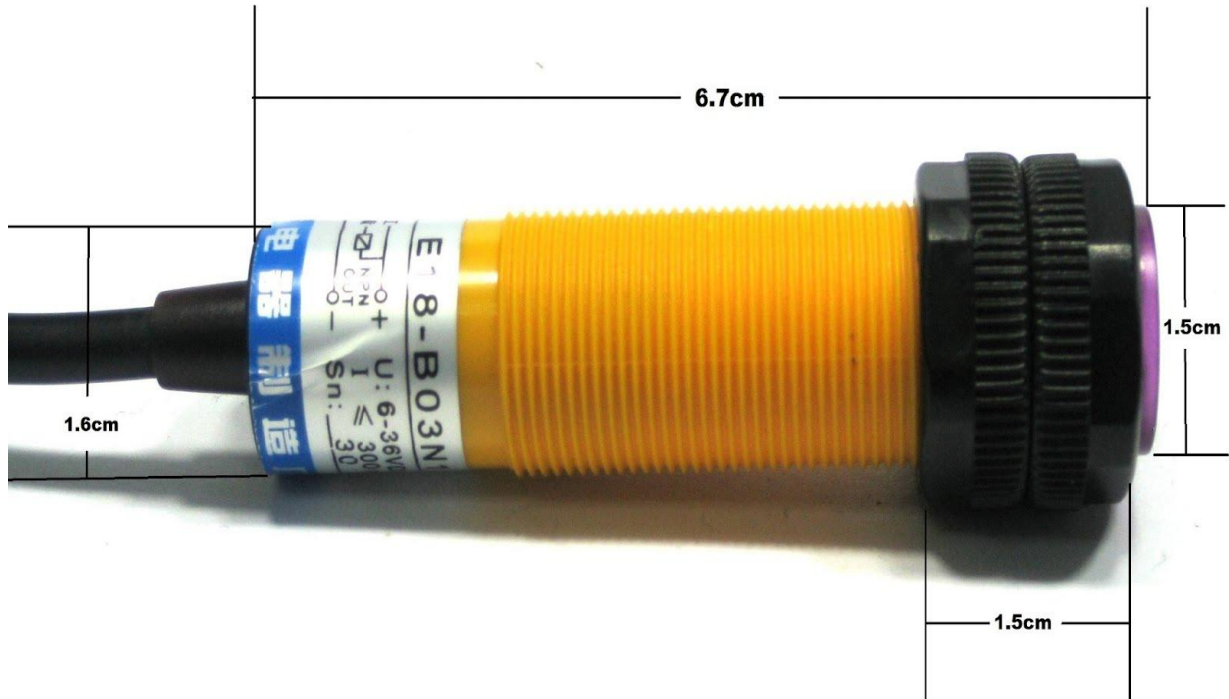

4.2 Product Layout

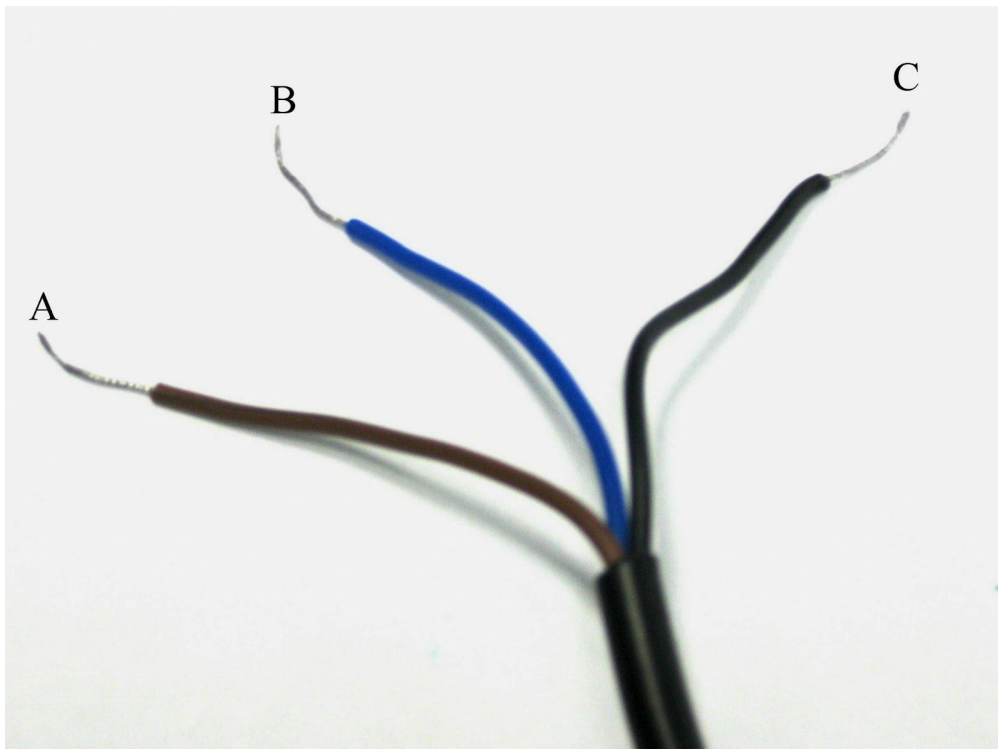

Label	Function
A	Connect VCC(+)
B	Connect GND(-)
C	Connect Output Signal (S)

A- User may supply 6V-36V to SN-E18-B03N1, the typical voltage is 12V.

B-User may connect the GND (-) of SN-E18-B03N1 to the Ground (0V) of the control board.

C-User may connect output signal to an I/O pin of microcontroller which set to INPUT mode. The output signal of Digital Infrared Sensor is needed to be pull high as it is NPN output. The module will output a HIGH if no object is detected and a LOW if an object is detected.

Note: Although the specification stated it is NPN output, we notice the sensor itself is being pull-up internally. Causing the output pin is being pull up to power pin. So if 12V is supply, you will get ~12V at output when no obstacle is detected.

5. GETTING STARTED

5.1 Connecting and Testing

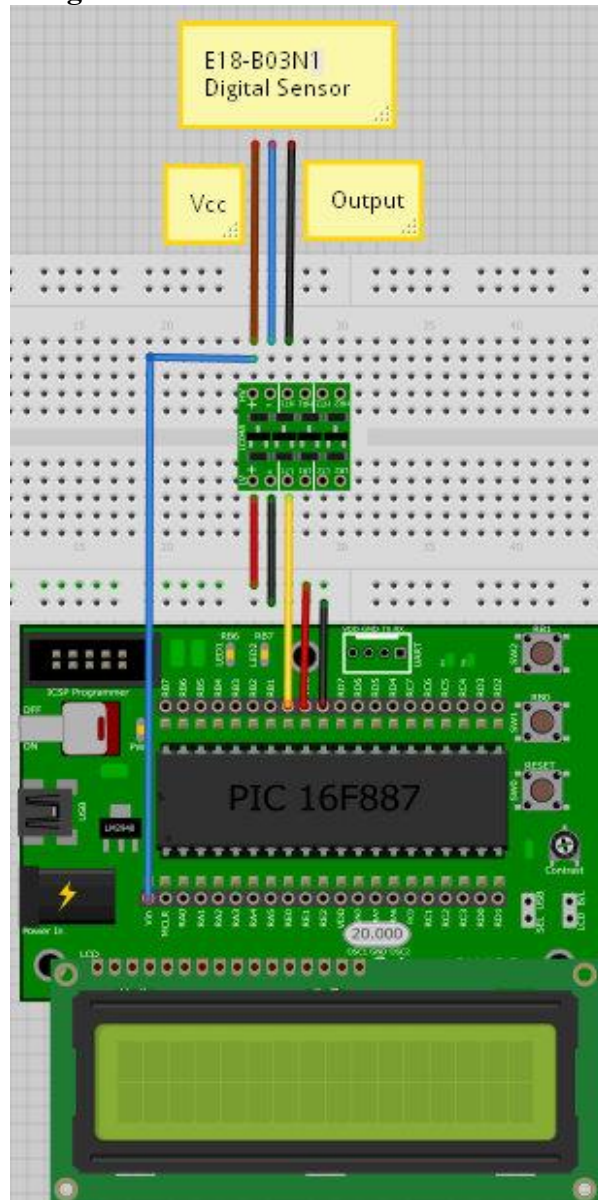

Example 4.1 Example interface for Digital Infrared Sensor (With SK40C), using [LC04A](#) as level shifter.

Part	Description
Digital Infrared Sensor Connector	Connects to Digital Infrared Sensor, pin 1 to output (Black Color), pin 2 to GND (Blue color) and pin 3 to Vcc (Brown color)
Vcc	Connects to Vcc (+6V to +36V), 5V is possible too.
LC04A	As logic level shifter

SK40C	The output of sensor is shifted to logic 5V via LC04A and go into RB0 of SK40C. RB0 is input of SK40C.
-------	--

The interface of Digital Infrared Sensor is shown in Figure 4.1, with reference to the schematic , the output signal which sends to microcontroller with LOW wherever there is a infrared detected and high if no object detect.

6. WARRANTY

- Product warranty is valid for 6 months.
- Warranty only applies to manufacturing defect.
- Damaged caused by miss-use is not covered under warranty
- Warranty does not cover freight cost for both ways.

Prepared by
Cytron Technologies Sdn. Bhd.
19, Jalan Kebudayaan 1A,
Taman Universiti,
81300 Skudai,
Johor, Malaysia.

Tel: +607-521 3178

Fax: +607-521 1861

URL: www.cytron.com.my

Email: support@cytron.com.my
sales@cytron.com.my